

## Open Frame Series 15" Open Frame Display

Model NO :OFD-150XN-VD



### Display Specifications

LCD Display	15" Active Matrix TFT color LCD
Active Display Area	304.128(H) x 228.096(V) mm
Resolution	1024 x 768
Pixels Pitch	0.297 x 0.297 mm
Brightness [ cd/m <sup>2</sup> ]	350 (Typ)
Contrast Ration	800 : 1(Typ.)
Viewing Angle	170° (H) / 160°(V)

### System

I/O Connectors	DC power input x 1 , VGA x 1 , DVI x 1
OSD Control	on the Rear Side

### Power Supply

Power Consumption	30 (watt)
Power Input	DC 12 V

### Mechanical

Construction	Metal Chassis
Mounting	Panel Mount or VESA Mount (75 x 75 Mount)
Dimension	399 x 299.5 x 35.5 (mm)
Net Weight	2.80 KGS

### Environmental

Operating Temperature	0~50°C ( 32 ~122 °F )
-----------------------	-----------------------

### Order Options

Optional Touch Panel	Resistive, Capacitive (RS232 or USB) .
----------------------	--



### Dimension

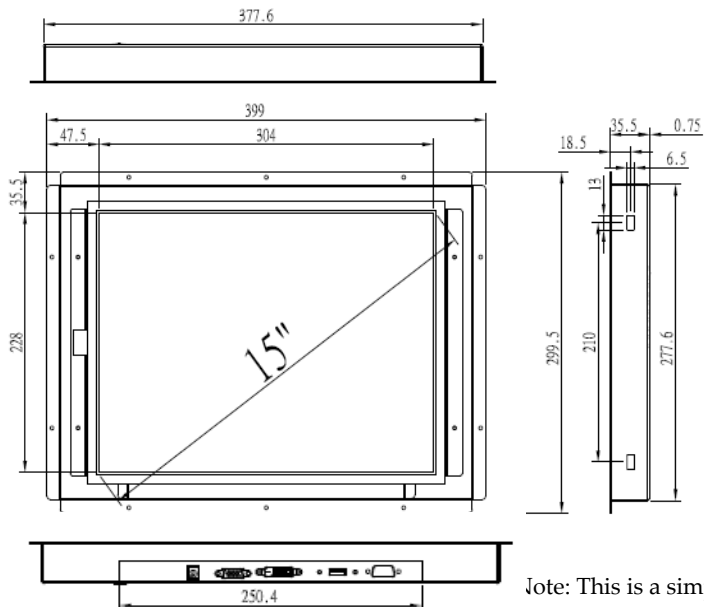

UNIT: mm

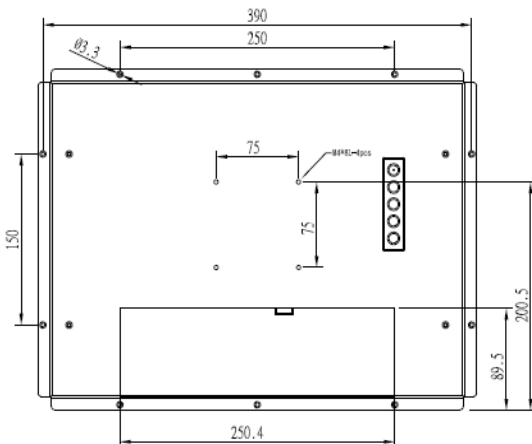

Note: This is a simplified drawing and some components are not marked in detail. Please contact us for product detail information.