

Open Frame Series - High brightness 1000nits

15" Open Frame Display

Model NO :OFD-150XN-VH



Display Specifications

LCD Display	15" Active Matrix TFT color LCD
Active Display Area	304.128(H) x 228.096(V) mm
Resolution	1024 x 3(RGB) x 768
Pixels Pitch	0.297 x 0.297 mm
Brightness [cd/m ²]	1000 (Typ)
Contrast Ration	700 : 1(Typ.)
Viewing Angle	170° (H) / 160°(V)

System

I/O Connectors	DC power x 1 , VGA (15 Pin Female D-SUB) x 1 ,DVI x 1
OSD Control	on the Rear Side

Power Supply

Power Consumption	30 (watt)
Power Input	DC 12 V

Mechanical

Construction	Metal Chassis
Mounting	Panel Mount or VESA Mount (75 x 75 Mount)
Dimension	399 x 299.5 x 35.5 (mm)
Net Weight	2.80 KGS

Environmental

Operating Temperature	0~50°C (32 ~122 °F)
-----------------------	-----------------------

Order Options

Optional Touch Panel	Res TP, Capacitive TP, Anti-vandal glass 7.2mm
----------------------	--

Dimension

UNIT: mm

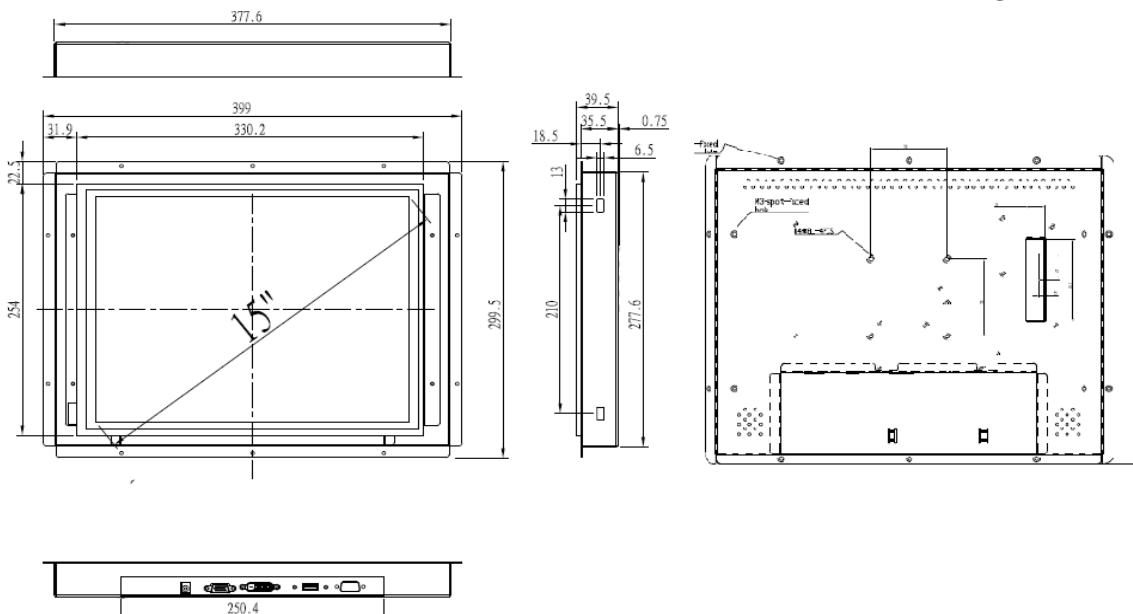

*Note: This is a simplified drawing and some components are not marked in detail.
 Please contact us for product detail information.